



5" - 14 gauge spun aluminum ball
 gold anodized

Single sheave truck, cast aluminum
 revolving, non-fouling type

2 Bronze swivel snaps with covers
 per halyard

1 Set of halyard: #10 poly

Optional Sealed Bearing Truck Available



1 - 9" Cast aluminum cleat

Aluminum flash collar

3000 PSI concrete

Hardwood wedges
 (supplied by others)

Dry sand tightly tamped
 after aligning pole

Foundation sleeve -16 ga
 hot dip galvanized steel

Steel centering wedges

1/4" Steel base plate

1/4" Steel support plate
 welded to grounding spike

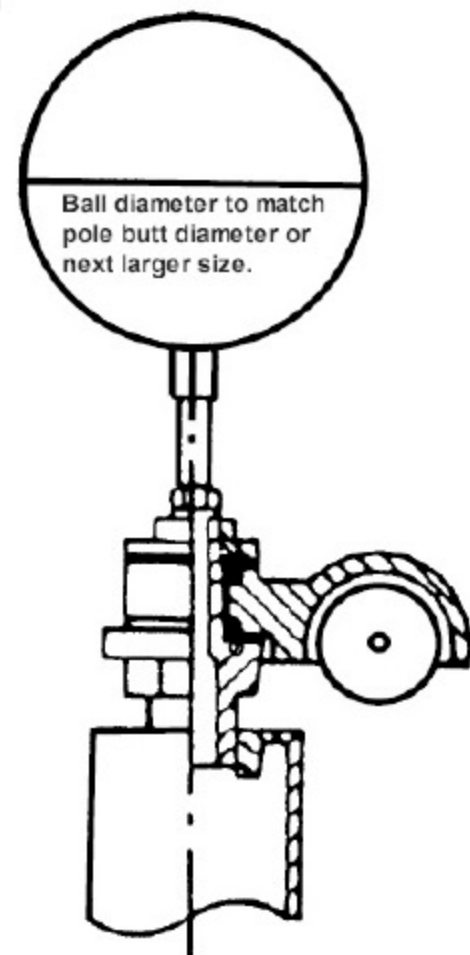
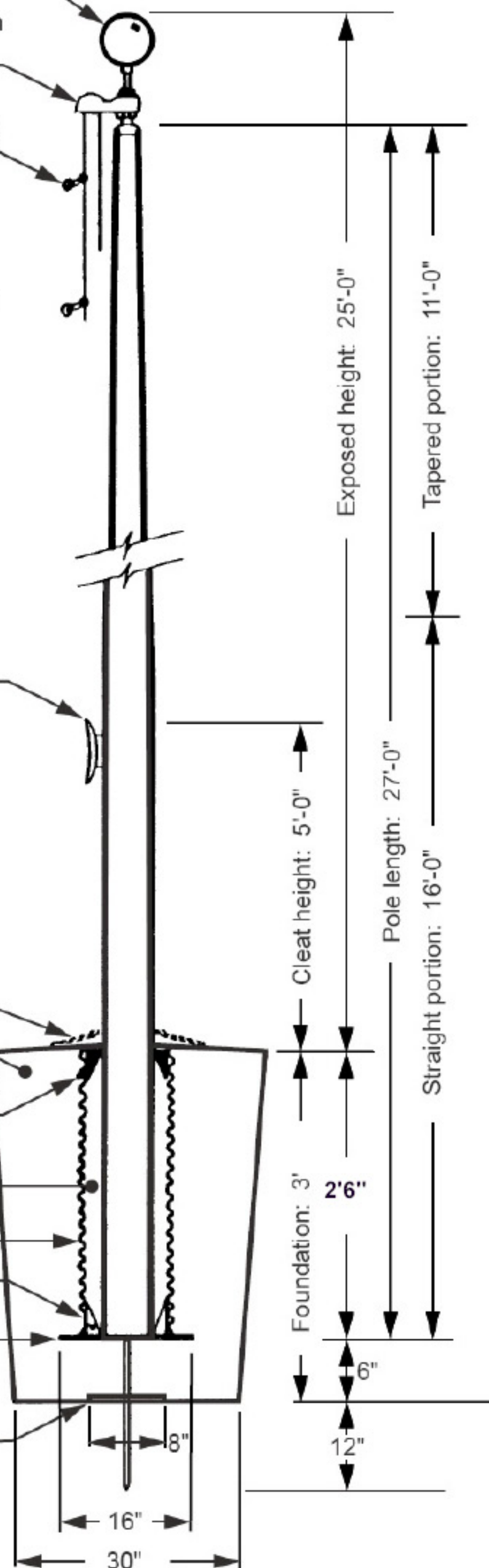

Truck Detail

Aluminum body
 Stainless steel ball bearings
 Aluminum sheave
 Cast aluminum spindle

All shafts with overall
 length of more than
 38'-6" are shipped in
 two sections.

Each section matched marked
 for field assembly. Exposed
 portion of jam sleeve must
 be **well lubricated** prior to
 assembly.

1-1/2" maximum shop
 gap allowed for field fitting
 (ram for tight joint)

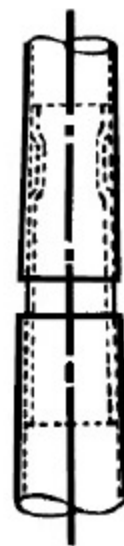

Anchor A25 25050125

Project:	Ground set tapered aluminum flagpole: ALLOY: 6063T6	Anchor Flag And Flagpole 2044 Hwy 9 West Longs, South Carolina 29568 800-637-3002 / 843-756-9161 FAX. 843-756-9161	Date:
Location:	Exposed height: 25'-0" Pole length: 27'-0"		Revision:
Architect:	Ship in 1 section Butt diameter: 5"		
Contractor:	Top diameter: 3" Wall thickness: .125"		
Customer:			Job: