



12" - 14 gauge spun aluminum ball
gold anodized

Double sheave truck, cast aluminum
revolving, non-fouling type

3 Bronze swivel snap with covers
per halyard

1 Set of halyards: #12 poly

We recommend our HD Dual Sealed Bearing top
head for these poles for a lifetime of trouble
free service. Unit has stainless steel spindle
and sealed bearing sets. Adds \$410.00 to cost.



Also available with double sheave

1 - 9" Cast aluminum cleats

Aluminum flash collar

3000 PSI concrete

Hardwood wedges
(supplied by others)

Dry sand tightly tamped
after aligning pole

Foundation sleeve -16 ga
hot dip galvanized steel

Steel centering wedges

1/4" Steel base plate

1/4" Steel support plate
welded to grounding spike

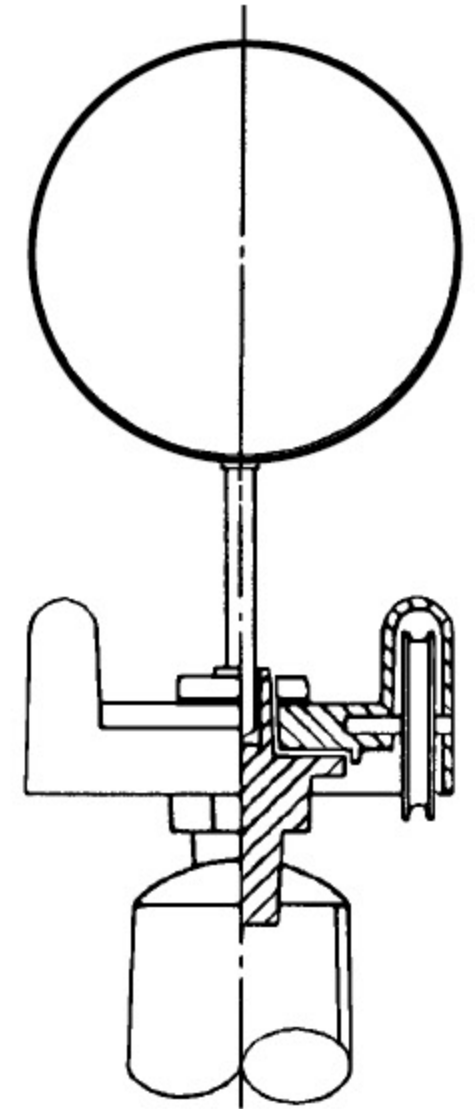
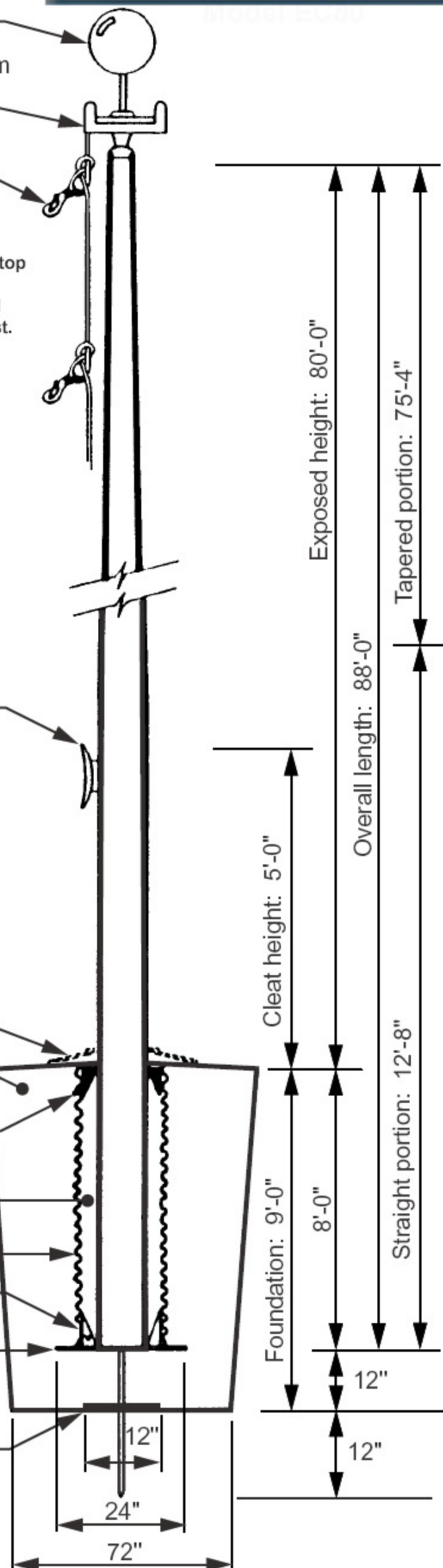

Truck Detail

Revolving, non-fouling truck
Cast aluminum body
Stainless steel ball bearings
 Nylon sheaves
Cast aluminum spindle

All shafts with overall
length of more than
38'-6" are shipped in
two sections.

Each section matched marked
for field assembly. Exposed
portion of jam sleeve must
be **well lubricated** prior to
assembly.

1-1/2" maximum shop
gap allowed for field fitting
(ram for tight joint)

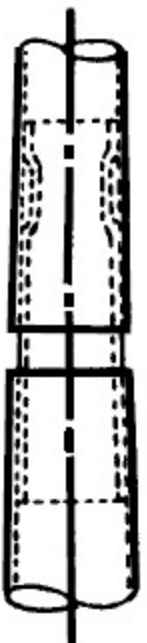

Anchor A80 80120375

Project:	Ground set tapered aluminum flagpole: ALLOY: 6063T6	Anchor Flag And Flagpole	Date:
Location:	Exposed height: 80'-0" Overall height: 88'-0"	2044 Hwy 9 West	Revision:
Architect:	Ship in 3 sections Butt diameter: 12"	Longs, South Carolina 29568	
Contractor:	Top diameter: 4" Wall thickness: .375"	800-637-3002 / 843-756-9161	
Customer:	Finish: 100 grit polish	FAX. 843-756-9161	Job: